

**SE Spa Electrics®**

***retro***®

REPLACEMENT LED POOL LIGHT



**POOL LIGHT (UNIVERSAL)  
INSTALLATION**

**SE Spa Electrics**

**R8** **INSTALLATION &  
OWNER'S MANUAL**

U.S. Patent No. 11746996

# CONTENTS

PRE-INSTALLATION CHECK 3

READ THIS FIRST 5

TOOLS REQUIRED 6

INCLUDED PARTS 7

INSTALLATION A: CONNECTION TO CABLE 8

B: ATTACH NICHE ADAPTOR 17

C: CONNECT LUMINAIRE 20

D: FIT LIGHT INTO NICHE 21

POST INSTALLATION CHECK 22

WINTERIZATION 23

TROUBLESHOOTING 26

ELECTRICAL GROUNDING 27

FCC COMPLIANCE STATEMENT 27

KEY DIMENSIONS 28



## NOTICE

FRESH WATER USE ONLY.  
NOT INTENDED FOR OPERATION OUT OF WATER.

# PRE-INSTALLATION CHECK

## 1 CHECK POWER SUPPLY

**1A:** IF THE POOL LIGHTS ARE DIRECTLY CONNECTED TO A 120V POWER SUPPLY, DO NOT CONTINUE INSTALLATION

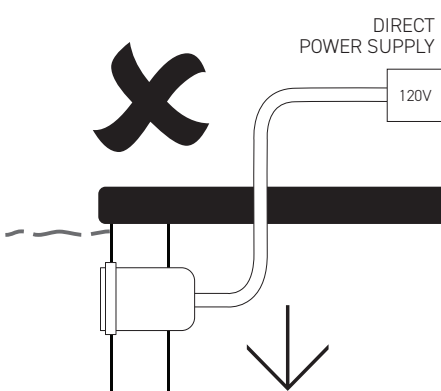

**1B:** A 12V AC TRANSFORMER **MUST** BE INSTALLED BETWEEN THE 120V POWER SUPPLY AND POOL LIGHT

**2A:** IF THE POOL LIGHTS ARE CONNECTED TO A TRANSFORMER CHECK THAT IT MEETS STEP 2 REQUIREMENTS

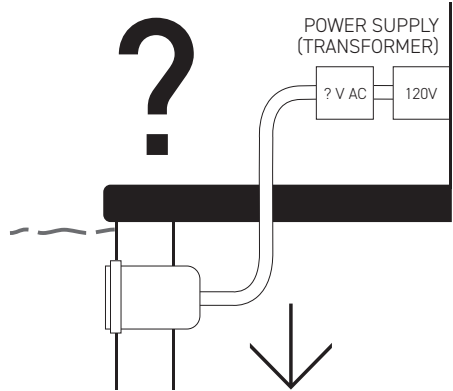

**2B:** IF THE TRANSFORMER DOES NOT MEET THE REQUIREMENTS, IT WILL REQUIRE REPLACEMENT

## 2 ADD TRANSFORMER (IF NEEDED)

### EXISTING TRANSFORMER MUST BE:

- UL Listed Isolating Low Voltage power supply, evaluated for swimming pool use
- Installed as per current NEC wiring rules
- 12-14v AC output
- Minimum 50W per Retro Series Pool light
- In good working order

### EXISTING TRANSFORMER MUST NOT BE:

- DC or LED Driver
- Electronic or Switch mode
- Weather damaged or in otherwise poor condition

# PRE-INSTALLATION CHECK

## 3 CHECK PLUG CABLE THICKNESS

RETRO UNIVERSAL CAN FIT CABLES FROM 9/32" (7mm) UP TO 9/16" (14mm) DIAMETER

Max  $\emptyset$   
9/16 inch  
(14mm)



## 4 CHECK BONDING

ENSURE BONDING IS SECURE AT BACK OF NICHE  
**DO NOT CUT** THE BONDING CABLE

**DO NOT DISTURB** THE BONDING CABLE WHEN WORKING WITH THE PLUG CABLE

### ELECTRICAL GROUNDING



DUE TO ITS PLASTIC HOUSING DESIGN, THE RETRO UNIVERSAL LUMINAIRE DOES NOT REQUIRE GROUNDING / BONDING.

**SEE ELECTRICAL GROUNDING SECTION FOR MORE INFORMATION**

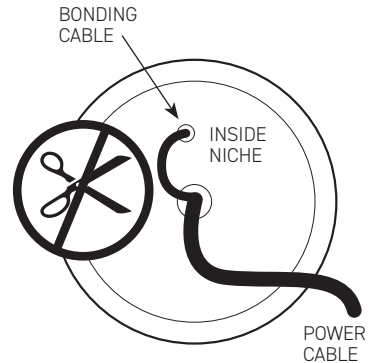

## 5 CHECK NICHE DIAMETER

THE RETRO UNIVERSAL IS DESIGNED TO WORK WITH 8 INCH OUTSIDE DIAMETER NICHE

8 inch OD  
DIAMETER

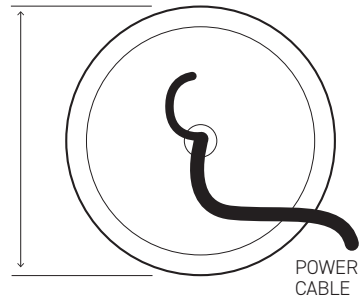

# READ THIS FIRST

Congratulations on your purchase of a Spa Electrics **Retro Universal** Series Pool Light. This light has been designed in conjunction with leading pool professionals across the USA and manufactured solely in Australia.

The Retro Series Pool light is designed to quickly and easily replace existing LOW VOLTAGE, 8" Pool Light fittings from major brands. Its patented cam-lock system allows for simple installation in situations where the existing niche hardware has been damaged or is no longer serviceable.

**For safe and proper installation, please read this manual in full before commencing installation and use only the parts (screws, plugs, sealant etc) as provided.**

**For operating instructions, please refer to the MULTI PLUS Operating Manual.**  
(Provided)

**NOTE:** The use of DC / Electronic (or Switch mode) power supplies is not permitted as they can cause disruptions in the lights normal operation & in some cases damage the lights internal electronic components. For more information, please contact Spa Electrics Inc.

## WARNING



- The **Retro Universal** Light must be water cooled at all times. DO NOT switch the light on until installation is complete and the light is fully submerged in water.
- Ensure sufficient cable is coiled behind the light to allow for servicing (~12 to 24inch)
- Ensure only circular cable not exceeding 14mm diameter is connected to the **Retro Universal** Light. The use of Fig. 8 or non circular cable will not seal correctly & will void the product warranty.
- The **Retro Universal** LED Light does not contain any user serviceable parts, opening the light will void the product warranty.
- Pool chemicals & pH levels: Due to the corrosive nature of unbalanced pool chemicals, Spa Electrics strongly recommend that your pool water is balanced prior to installing your pool lights or any plastic or stainless steel components, and tested weekly to maintain these levels. pH levels should be maintained between 7.2- 7.6 at all times to ensure the longevity of these components.
  - Failure to do so can result in chemical damage to the light housing and pool fittings, including stainless steel components.
  - Please note: Lights or components found to have excessive chemical damage will not be covered under our manufacturer's warranty policy

# TOOLS REQUIRED

- ✓ Phillips Head Screwdriver
- ✓ Small Flat Blade Screwdriver

## IMPORTANT NOTES



- The use of power tools during installation is **not** recommended as these devices can cause faults and damage to light components.
- All installation steps should be carried out with manual tools only.
- The enclosed images are for illustrative purposes only. Appearances of parts and assemblies may vary from the enclosed illustrations.
- Please contact your reseller if you have any questions regarding the correct installation of this product.

## WINTERIZATION



- Lights must be removed from the pool wall and cable disconnected via plug connection & stored in a safe place.
- Winterization Cover must be fitted to Plug Top prior to reinstalling into the niche for winter.
- Unless niche/conduit connection is adequately sealed (i.e. via included cable gland components), the pool water level must be drained down 12" below the lowest light(s) position in the pool wall.
- All conduits should be checked for accumulated water and drained if required.
- Follow instructions in the Winterization section OR consult your local pool professional for a complete pool winterization process.

## PRODUCT SUPPORT AND INFORMATION

For the most up to date installation and contact information, please visit [www.spaelectrics.com](http://www.spaelectrics.com)

# INCLUDED PARTS

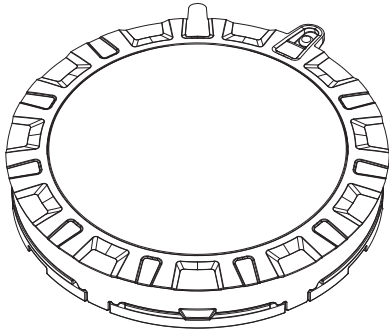

LIGHT ASSEMBLY

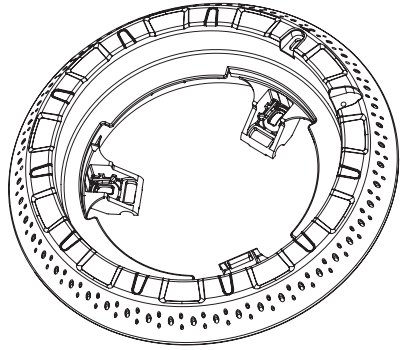

NICHE ADAPTOR

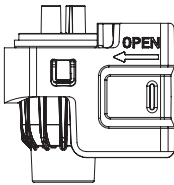

QUICK CONNECT PLUG  
(PROVIDED AS COMPONENTS SEE BELOW)



LIGHT MOUNTING SCREW (SPARE)



NICHE ADAPTOR MOUNTING SCREW  
(NOT REQUIRED)



LANOLIN

Also included is a Winterization Plug Cap if required for seasonal upkeep.

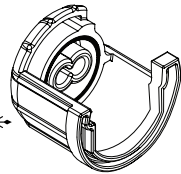

## CONNECTOR PLUG COMPONENTS

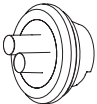

Screw Terminal End with filling screws attached



Strain Relief Clip

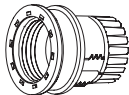

Connector Barrel



Glands x 3 sizes provided



Gland Nut

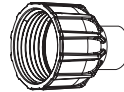

Large Gland Nut (also supplied)

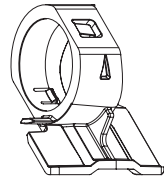

Connector Collar



1X INSTALLATION MANUAL



1X WARRANTY CARD



1X MULTIPLUS MANUAL

## REQUIRED PART (NOT INCLUDED)



**UL LISTED ISOLATING LOW VOLTAGE POWER SUPPLY, EVALUATED FOR SWIMMING POOL USE.**

Installed as per current NEC wiring rules. 12~14v AC output. Minimum 50W per Retro Series Pool Light.

Spa Electrics recommends the use of its "LVX Series" safety transformers with the Retro Series lights.

# A: CONNECTION TO CABLE

**STOP! WARNING  
ELECTROCUTION**



CHECK POWER IS  
TURNED OFF FIRST

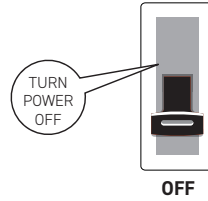

TURN OFF BREAKER  
TO POOL LIGHT  
TRANSFORMER

## 1 REMOVE EXISTING LIGHT

REMOVE EXISTING LIGHT FROM NICHE AND  
BRING TO THE SURFACE FOR CONNECTION

**ENSURE YOU DON'T DISTURB THE  
BONDING CABLE**

ALL CABLE CONNECTIONS ARE TO BE DONE  
AT SURFACE LEVEL AND OUT OF WATER

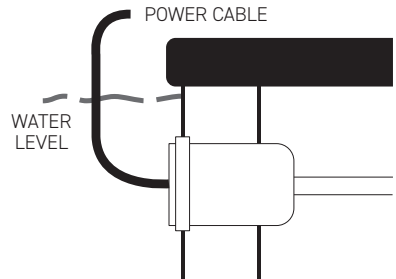

## 2 DISCONNECT EXISTING LIGHT

DISCONNECT LIGHT FROM  
POWER CABLE

CUT POWER CABLE AS CLOSE  
TO BACK OF EXISTING LIGHT AS  
POSSIBLE

ENSURE BONDING CABLE IS NOT  
CUT OR DISTURBED

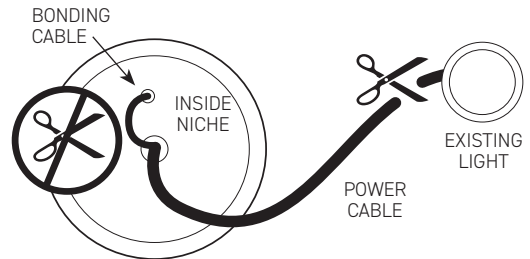

# 3

## CABLE PREPARATION

STRIP POWER CABLE TO SPECIFIED LENGTH

### NOTE



IF CABLE LENGTH ALLOWS, CUT CABLE BACK UNTIL FRESH COPPER APPEARS.

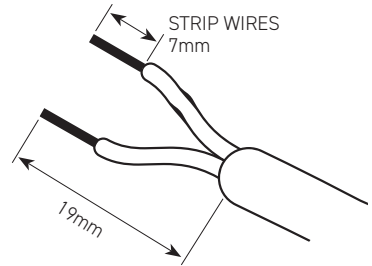

### NOTE



THE EXISTING CABLE MAY INCLUDE A GROUND WIRE (GREEN), CUT THIS WIRE OFF AS THIS IS NOT REQUIRED FOR CONNECTION TO THE SPA ELECTRICS LIGHT AND DOESN'T FOLLOW THE CABLE PREPARATION STEP.

# 4

## START ASSEMBLY OF CONNECTOR PLUG

### LANOLIN USE



GENTLY WARM  
LANOLIN  
BEFORE USE

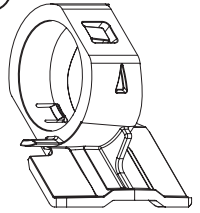
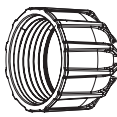
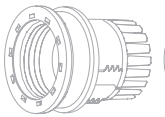
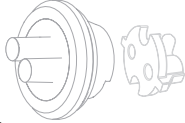

GLAND NUT

LARGE GLAND NUT

CONNECTOR COLLAR

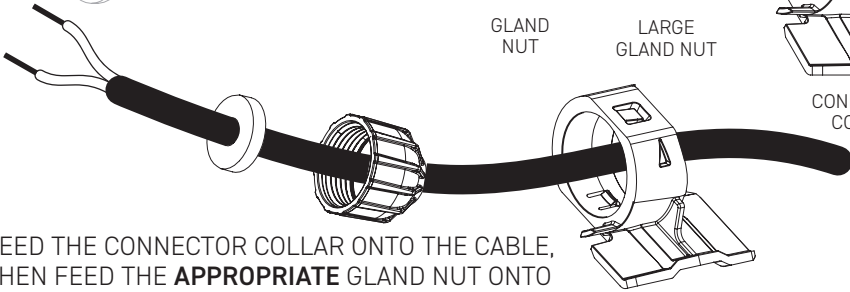

FEED THE CONNECTOR COLLAR ONTO THE CABLE, THEN FEED THE **APPROPRIATE** GLAND NUT ONTO THE CABLE

# 5

## CHOOSE THE APPROPRIATE GLAND

SELECT THE APPROPRIATE CABLE GLAND FROM THE THREE SUPPLIED THAT SNUGLY FITS THE EXISTING POWER CABLE WITHOUT BULGING

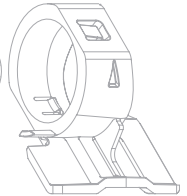
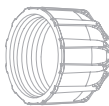
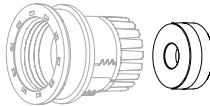

GLANDS X 3 SIZES PROVIDED



SMALL GLAND  
RED



MEDIUM GLAND  
BLUE



LARGE GLAND  
GREEN

THE GLAND FITMENT SHOULD BE FIRM OVER THE CABLE WITHOUT BULGING OR DEFORMING THE GLAND

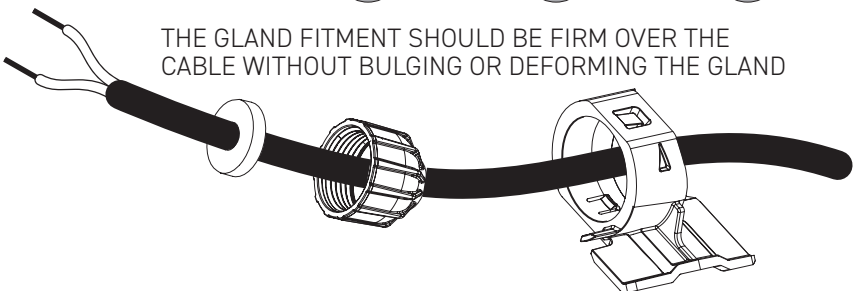

# 6

## CONTINUE ASSEMBLY OF CONNECTOR PLUG

FEED THE CONNECTOR BARREL ONTO THE CABLE

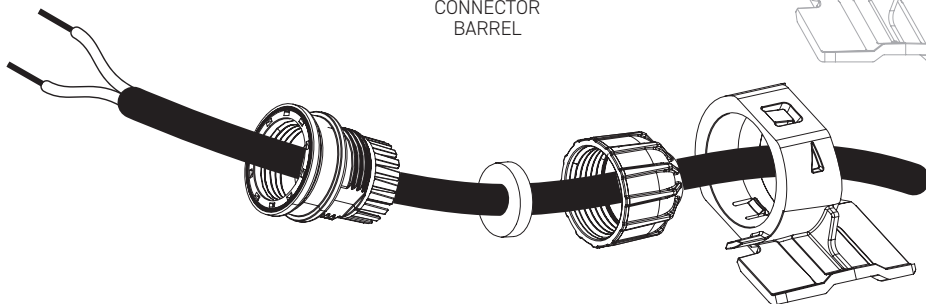
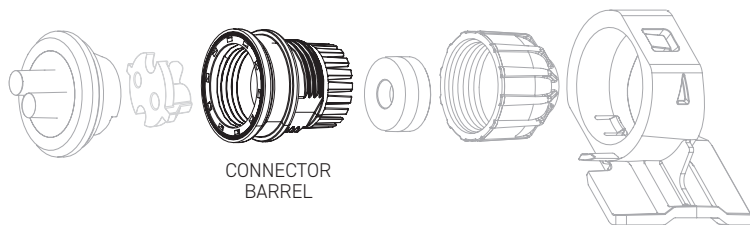

# 7

## CHECK SCREWS ON SCREW TERMINAL END

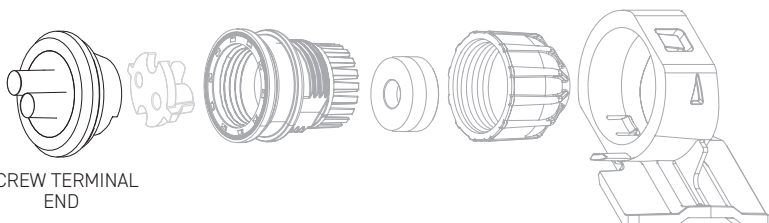

CHECK IF SCREWS ARE PRESENT IN THE TOP OF THE SCREW TERMINAL END

### WITH SCREWS

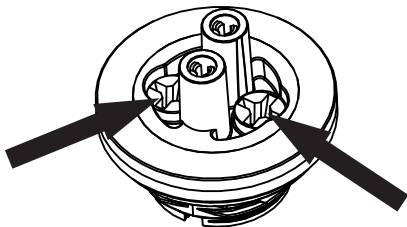

USE A MANUAL PHILLIPS HEAD SCREWDRIVER TO ENSURE THAT THE 2 SCREWS INDICATED ARE FULLY SEATED. PROCEED TO STEP 8.

### WITHOUT SCREWS

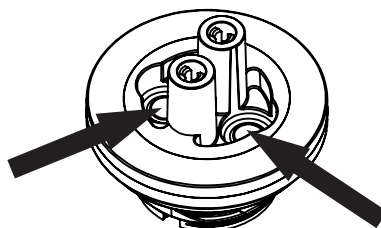

CHECK THERE ARE NO HOLES IN THE INDICATED LOCATIONS.

PROCEED TO STEP 8.

# 8

## STRAIN RELIEF CLIP

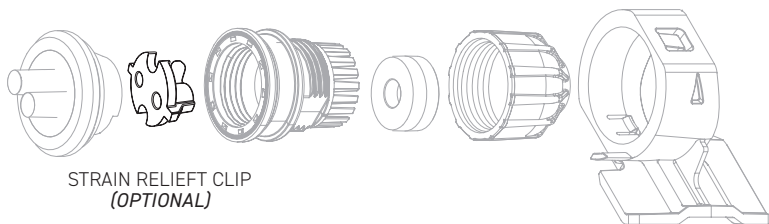

STRAIN RELIEF CLIP  
(OPTIONAL)

**OPTION 1:** WHEN USING THE MEDIUM OR LARGE CABLE GLANDS, THE STRAIN RELIEF CLIP IS NOT REQUIRED. FOLLOW STEP 9A (IGNORE STEP 9B).

**OPTION 2:** THE STRAIN RELIEF CLIP MUST BE USED WHEN THE SMALL CABLE GLAND IS USED. FOLLOW STEP 9B (IGNORE STEP 9A).

### STRAIN RELIEF CLIP REQUIRED



SMALL  
GLAND



MEDIUM  
GLAND



LARGE  
GLAND

# 9A

## CONNECT THE SCREW TERMINAL END

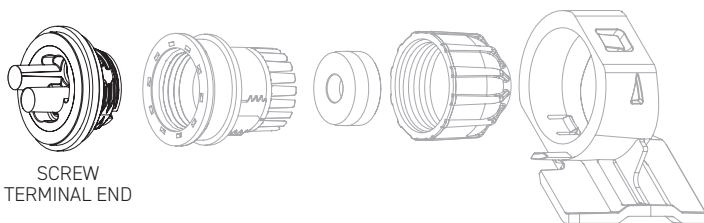

SCREW  
TERMINAL END

- 1: FEED THE TWO STRIPPED CABLE ENDS THROUGH THE TWO HOLES IN THE BACK OF THE SCREW TERMINAL END

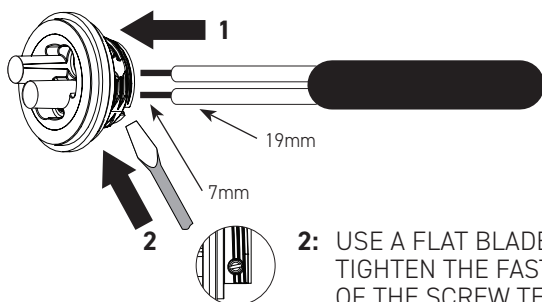

- 2: USE A FLAT BLADE SCREWDRIVER TO TIGHTEN THE FASTENERS ON EITHER SIDE OF THE SCREW TERMINAL

# 9B

## CONNECT THE SCREW TERMINAL END

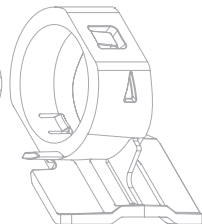
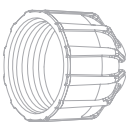

**1:** ATTACH THE STRAIN  
RELIEF CLIP TO THE  
SCREW TERMINAL END

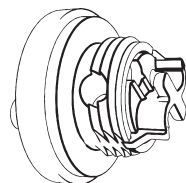
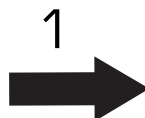
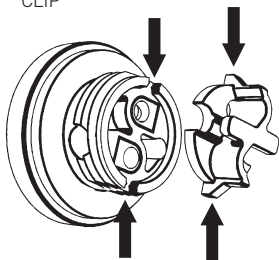

**2:** FEED THE TWO STRIPPED CABLE ENDS  
THROUGH THE TWO HOLES IN THE BACK OF  
THE SCREW TERMINAL END

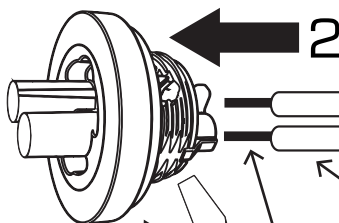

3/4" (19mm)

9/32" (7mm)

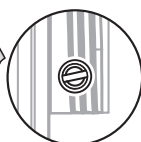

**3:** USE FLAT BLADE SCREWDRIVER TO  
TIGHTEN THE FASTENERS ON EITHER  
SIDE OF THE SCREW TERMINAL

**4:** TWIST THE SCREW TERMINAL AND  
LOOP CABLE ENDS UNDER THE STRAIN  
RELIEF CLIP

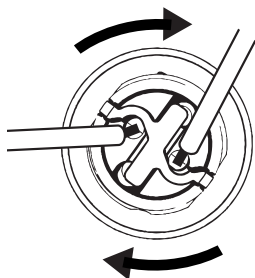

# 10

## START ASSEMBLY OF CONNECTOR PLUG

CAREFULLY THREAD CONNECTOR BARREL ONTO SCREW TERMINAL AND TIGHTEN FIRMLY BY HAND

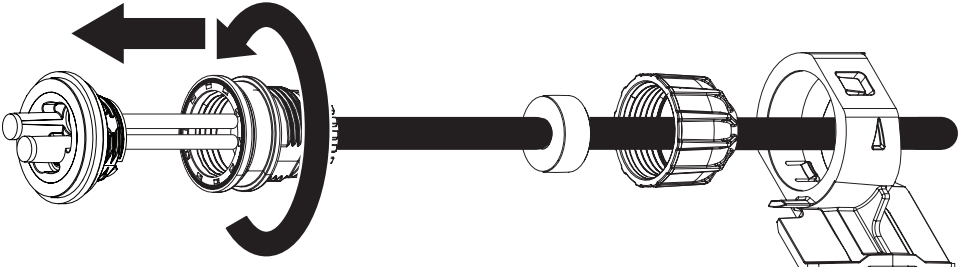

LEAVE THESE PARTS DISASSEMBLED UNTIL AFTER ADDING LANOLIN

# 11

## ADD LANOLIN

### LANOLIN USE



GENTLY WARM  
LANOLIN  
BEFORE USE

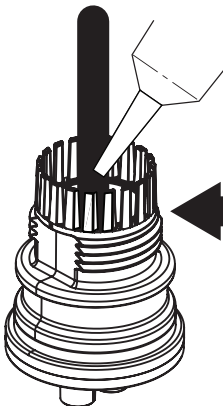

FILL BACK OF CONNECTOR BARREL WITH LANOLIN UP TO THE INDICATED POINT

FILL TO HERE  
(ALLOWING ROOM FOR GLAND)

# 12

## CONTINUE ASSEMBLY OF CONNECTOR PLUG

**1:** SEAT CABLE GLAND ALL THE WAY INTO CONNECTOR (DO A VISUAL CHECK TO MAKE SURE THERE IS A SEAL BETWEEN THE GLAND AND CABLE)

**2:** CAREFULLY THREAD GLAND NUT ONTO CONNECTOR BARREL

**3:** TIGHTEN GLAND NUT FIRMLY BY HAND

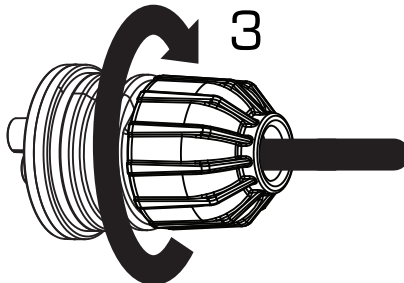
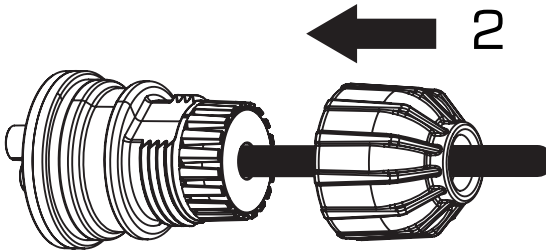
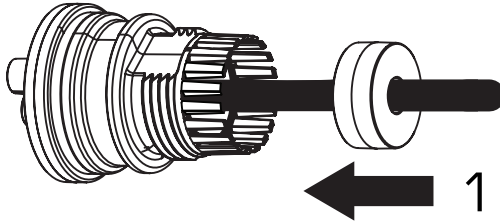

# 13

## CONTINUE ASSEMBLY OF CONNECTOR PLUG

- 1: DO A PULL TEST ON THE PLUG ASSEMBLY SO FAR, ALL ASSEMBLED PARTS SHOULD FEEL FIRM AND TIGHT
- 2: PUSH CONNECTOR COLLAR ALL THE WAY IN TO THE END UNTIL THERE ARE TWO DISTINCT "CLICKS". THE END WILL BE FREE TO ROTATE

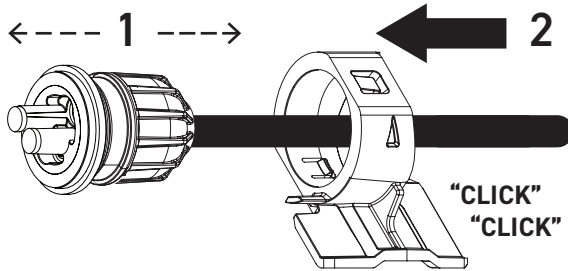

### ASSEMBLED VIEW OF CONNECTOR PLUG

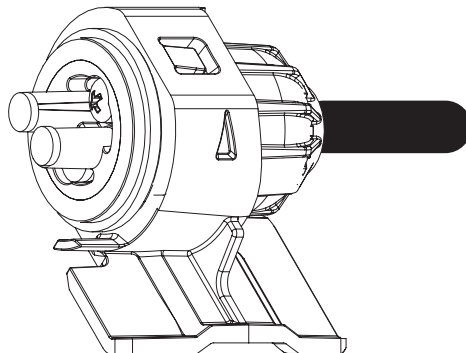

## B: ATTACH NICHE ADAPTOR

### 1 INSERT NICHE ADAPTOR

FEED THE CABLE THROUGH THE NICHE ADAPTOR

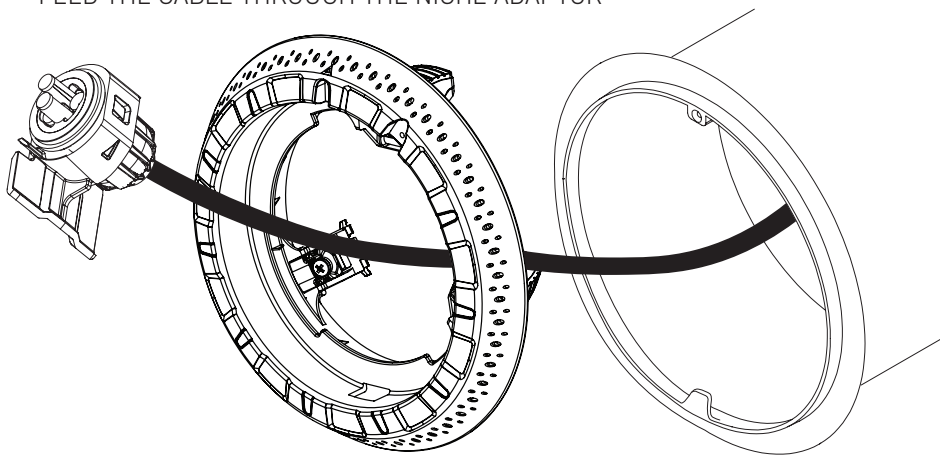

# 2

## ATTACH NICHE ADAPTOR

CENTRE NICHE ADAPTOR INTO NICHE, SO THE ARROW ON THE ADAPTOR IS POINTING UP

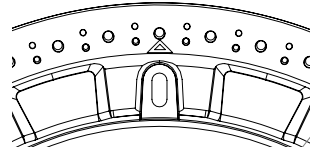

ENSURE THE CAM LOCKS GO INTO THE NICHE EASILY

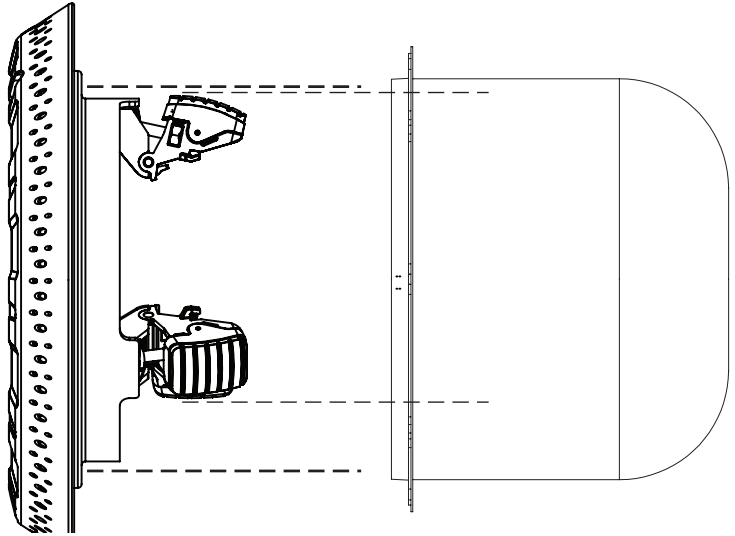

PUSH THE NICHE ADAPTOR INTO THE WALL SO IT SITS FLUSH AND IS FULLY INSERTED INTO THE NICHE

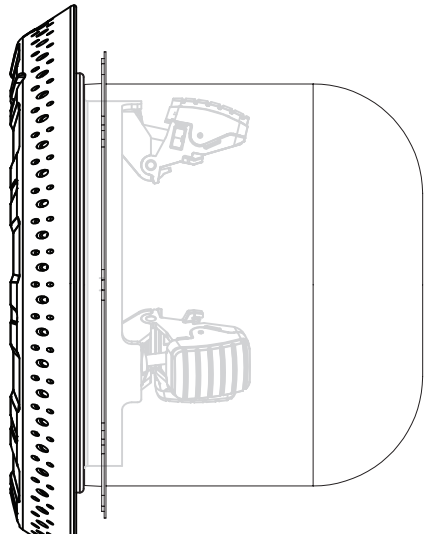

TIGHTEN THE THREE CAM LOCK SCREWS EQUALLY AND IN ROTATION, AS SHOWN, BY HAND UNTIL YOU FEEL THE NICHE ADAPTOR IS SECURE IN PLACE

**DO NOT OVERTIGHTEN.**

CHECK FOR SECURE FITTING, THE NICHE ADAPTOR SHOULD BE FIRM AND NOT ABLE TO MOVE EASILY BY HAND

GO TO **SECTION C: CONNECT LUMINAIRE**

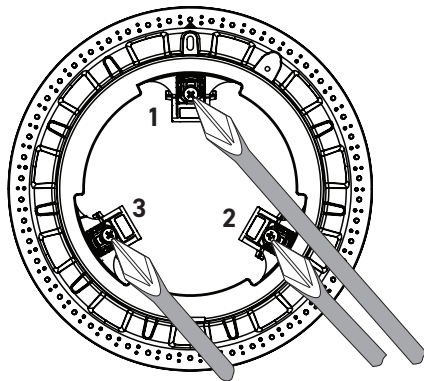

AS THE CAM LOCK SCREWS TIGHTEN, THE CAM LOCKS WILL MOVE IN AND UP, PULLING THE NICHE ADAPTOR FIRMLY INTO THE NICHE  
THE ADJUSTMENT RANGE OF THE CAMS ACHIEVE P.C.D. 7 ½" - 8 ¼" (190-210mm) (APPROX.)

MINIMUM  
CAM LOCK  
POSITION  
(LOOSE)

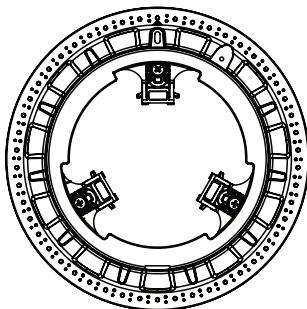

TIGHTEN SCREWS  
TO PULL NICHE  
ADAPTOR  
INTO NICHE

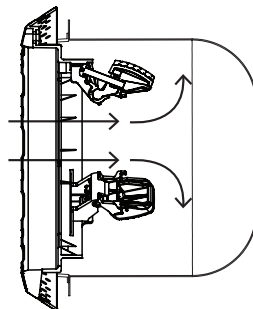

MAXIMUM  
CAM LOCK  
POSITION  
(TIGHT)

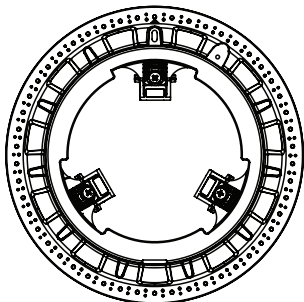

WHEN ALL CAM  
LOCKS ARE  
SCREWED TIGHT,  
THE CAM LOCKS SIT  
TIGHT AGAINST THE  
INSIDE OF THE  
NICHE, AND THE  
NICHE ADAPTOR IS  
PULLED FURTHER  
INTO THE WALL

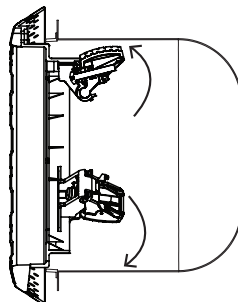

# C: CONNECT LUMINAIRE

## 1 ALIGN UP AND CONNECT CONNECTOR PLUG

1: TURN THE LUMINAIRE OVER TO SEE THE BACK

2: LOCATE THE CONNECTOR SOCKET

3: LINE UP THE TERMINALS OF THE SOCKET WITH THE CONNECTOR PLUG

4: SLIDE THE CONNECTOR PLUG FIRMLY INTO THE SOCKET WITH THE LEVER HORIZONTAL

5: FOLD THE LEVER UPRIGHT UNTIL IT LOCKS INTO PLACE VERTICALLY

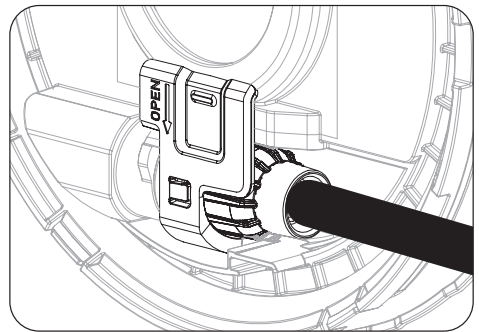
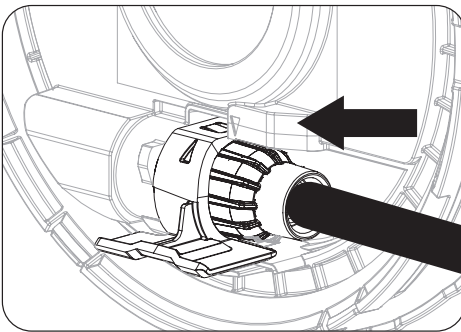
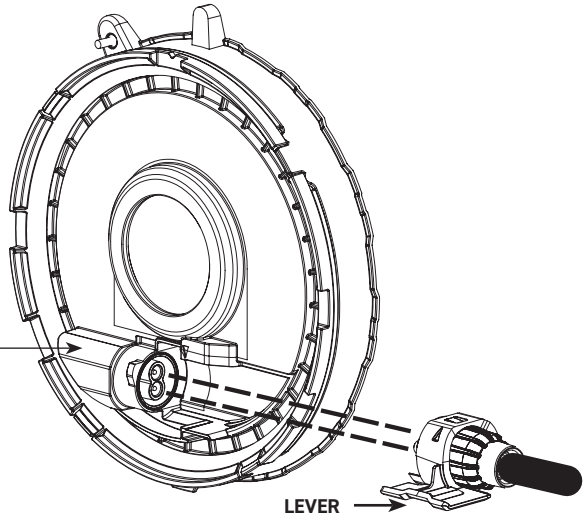

# D: FIT LIGHT TO NICHE

## 1 COIL EXCESS CABLE INTO NICHE



## 2 CONNECT LIGHT ASSEMBLY

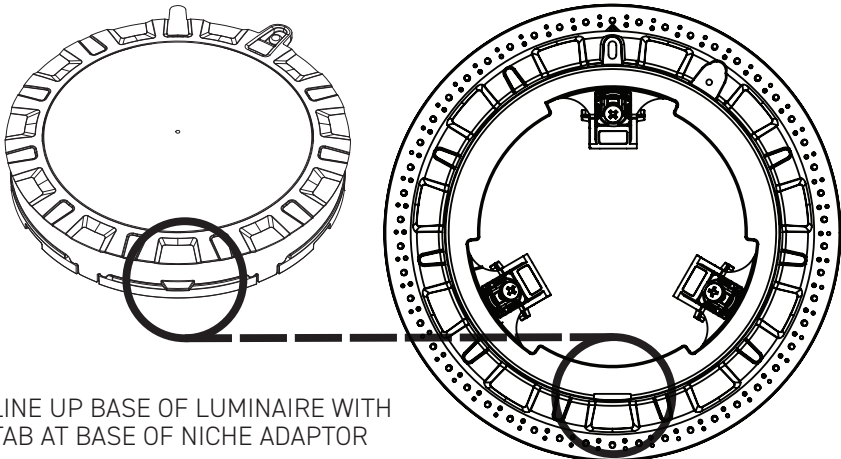

LINE UP BASE OF LUMINAIRE WITH  
TAB AT BASE OF NICHE ADAPTOR

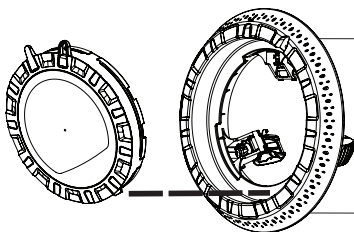

## 2

## CONNECT LIGHT ASSEMBLY CONTINUED

PUSH LUMINAIRE INTO PLACE  
ENSURING TAB LOCATES AT TOP  
AT 12 O'CLOCK

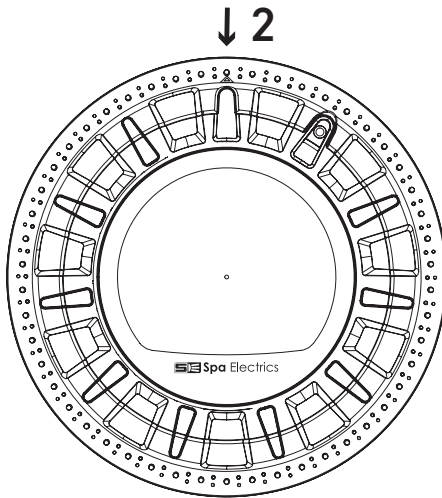

USE A SCREWDRIVER  
TO TIGHTEN THE LIGHT  
MOUNTING SCREW.

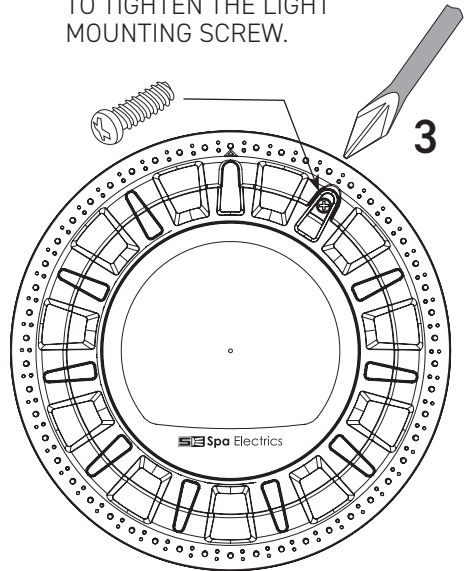

## POST INSTALLATION CHECK

### 1

### TEST SYSTEM

TURN ON POWER  
AND CHECK ALL  
WORKING CORRECTLY

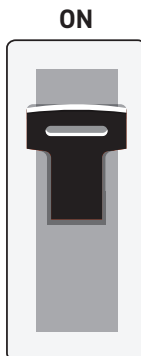

TURN ON BREAKER  
TO POOL LIGHT  
TRANSFORMER

# WINTERIZATION

## 1 DETACH THE LIGHT ASSEMBLY

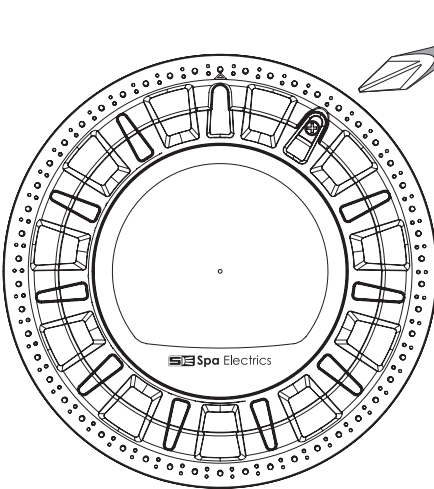

USE A SCREWDRIVER TO LOOSEN THE SCREW

## 2 PULL OUT LIGHT ASSEMBLY

PULL THE LIGHT ASSEMBLY FORWARD AND UP SO IT LIFTS OFF THE TAB AT BASE

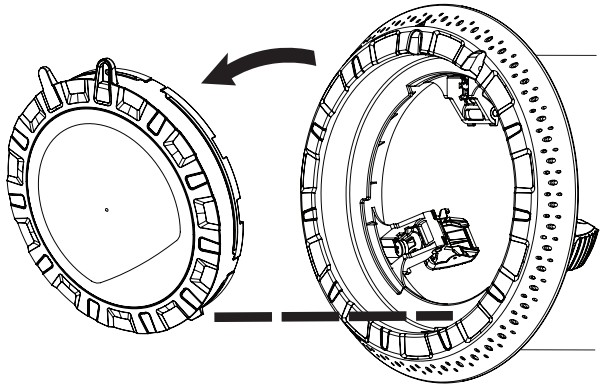

### NOTE



BRING ABOVE WATER LINE BEFORE DETACHING CABLE

### 3

## UNLOCK THE PLUG

FOLD THE LEVER DOWN SO THE LEVER IS HORIZONTAL

THE LIGHT ASSEMBLY IS NOW READY TO BE REMOVED

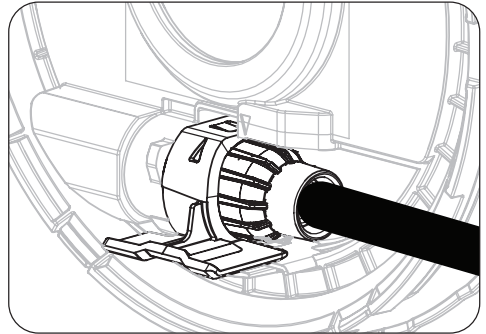
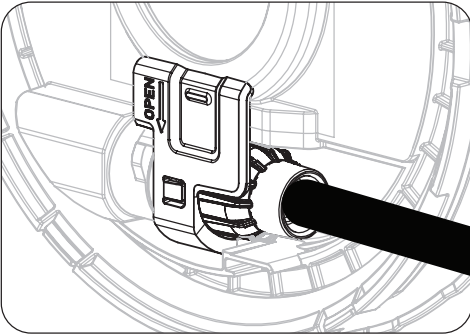

### 3

## REMOVE THE LIGHT ASSEMBLY

PULL OFF THE LIGHT ASSEMBLY

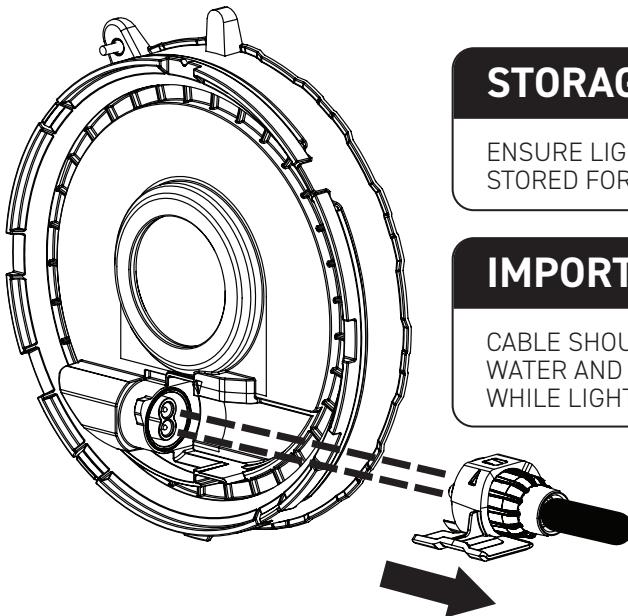

### STORAGE



ENSURE LIGHT ASSEMBLY IS SAFELY STORED FOR NEXT SEASON USE

### IMPORTANT NOTE



CABLE SHOULD BE SECURED ABOVE WATER AND WEATHER PROTECTED WHILE LIGHT IS DETACHED

# 5

## CONNECT WINTERIZATION PLUG CAP

LINE UP THE WINTERIZATION PLUG CAP TO THE PLUG

SLIDE INTO PLACE UNTIL SECURE

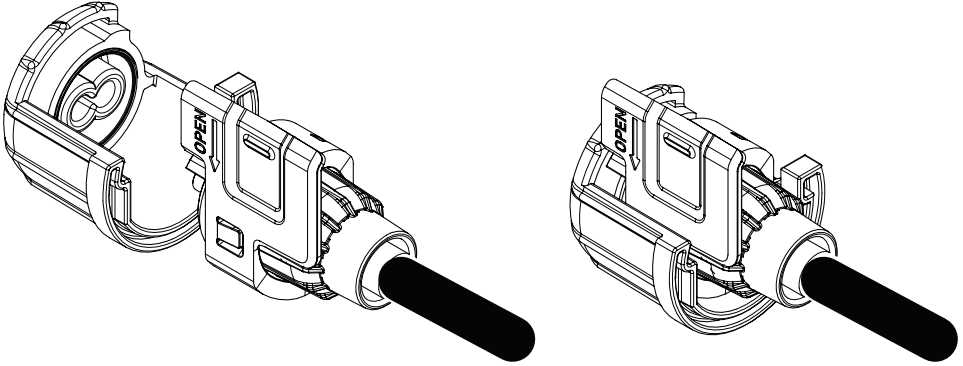

# 6

## LOCK ON WINTERIZATION PLUG CAP

FOLD DOWN THE LEVER TO LOCK IN PLACE

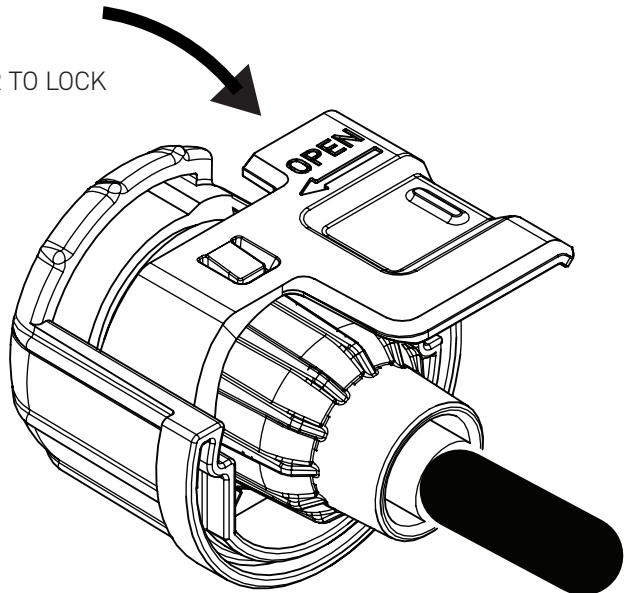

# TROUBLESHOOTING

ISSUE	REASON	ACTION
Light returns to WHITE colour during manual colour change.	Light synchronization process has been triggered.	Refer to MultiPlus User Guide instructions.
Light flashes red	Light over heating	Check light is fully submerged. Check vents are not obstructed
Light not operating (1)	Faulty connection to transformer	Ensure cable correctly connected to transformer terminals
Light not operating (2)	Mains power not connected	Check transformer is plugged in to GPO and switched on
Light not operating (3)	Damaged cable	Disconnect plug top and test voltage under load using multi-meter (ie. 50w 12v) Required voltage (11v ~ 13.5v)
Light not operating (4)	Transformer not working	Check fuses & test transformer using multimeter under load (ie.50w 12v)
Light colours not synchronized with controller	Incorrect operating mode selected.	Refer to MULTI PLUS setup procedure

If these issues cannot be resolved with the above recommended actions, please contact your local Spa Electrics reseller or Spa Electrics directly.

# ELECTRICAL GROUNDING

## Underwriters Laboratories (UL) Statement

Per the NEC, NFPA 70, Article 680.23 (B)(5), states that bonding shall not be required for luminaires that are listed for the application and have no non-current carrying metal parts. In addition, per Article 680.26 (B)(4), exception states that Listed low-voltage lighting systems with non-metallic forming shells shall not require bonding.

Therefore, luminaires with polymeric/non-current carrying metal parts are not required to be grounded / bonded.

## Manufacturers Statement

Spa Electrics **Retro Universal** luminaires with their plastic housing designs do not require grounding / bonding.

Spa Electrics **Retro Universal** lights have also been determined to comply with the applicable requirements for wet-niche, LED type Swimming Pool and Spa Luminaires.

# FCC COMPLIANCE STATEMENT

This device complies with part 15 of the FCC rules. Operation is subject to the following two (2) conditions:

- (1) This device may not cause harmful interference, and
- (2) this device must accept any interference received, including interference that may cause undesired operation.

**Note:** This equipment has been tested and found to comply with the limits for a Class B digital device, pursuant to part 15 of the FCC Rules. These limits are designed to provide reasonable protection against harmful interference in a residential installation. This equipment generates, uses and can radiate radio frequency energy and, if not installed and used in accordance with the instructions, may cause harmful interference to radio communications. However, there is no guarantee that interference will not occur in a particular installation. If this equipment does cause harmful interference to radio or television reception, which can be determined by turning the equipment off and on, the user is encouraged to try to correct the interference by one or more of the following measures:

- Reorient or relocate the receiving antenna.
- Increase the separation between the equipment and receiver.
- Connect the equipment into an outlet on a circuit different to that to which the receiver is connected.
- Consult the dealer or an experienced radio / TV technician for help.

**Do not make any changes or modifications to the equipment unless otherwise specified in the manual.**

# KEY DIMENSIONS

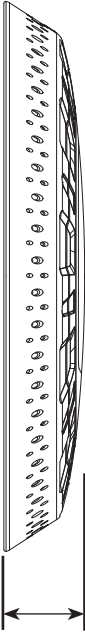
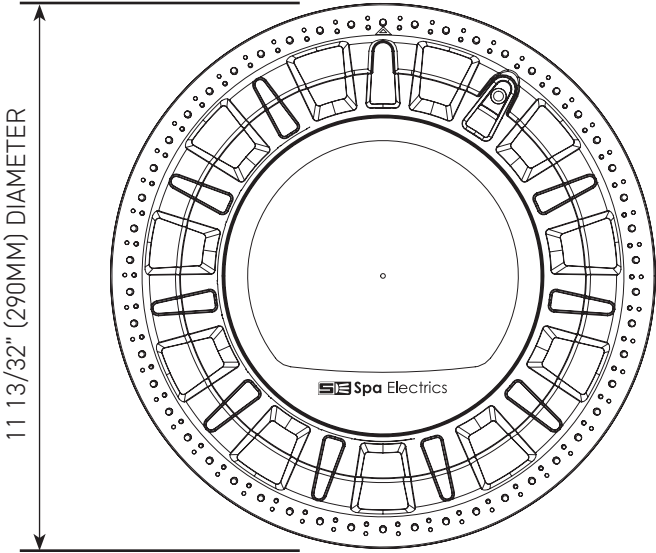

1 45/64" (42.6MM)









## IMPORTANT NOTE

PLEASE STORE THIS MANUAL IN A SAFE PLACE  
FOR FUTURE REFERENCE



 **Spa Electrics®**

*The underwater lighting specialists*

[spaelectrics.com](https://spaelectrics.com)

©COPYRIGHT 2024 SPA ELECTRICS INC.  
ALL RIGHTS RESERVED

US 2024 04 10